

E1E931S**E1E4045****SILICONE RUBBER / SPECIAL ELECTRONICS /
LOW LOADS**Natural frequency : (1)
15 to 25 Hz

DESCRIPTION

- High damped silicon elastomer (VHDS).
- Stainless Steel flange and centre axis.

APPLICATIONS

- Protection of electronic equipment, navigation equipment, control consoles, measuring instruments, onboard aircraft, trains and trucks.

CHARACTERISTICS

Natural frequency :

- axial : 15 to 25 Hz;
- radial : 10 to 20 Hz.

Maximum sinusoidal input amplitude at resonance frequency : $\pm 0,4$ mm.

Amplification factor at resonance < 4.

Operating temperature range : - 54 °C to + 150 °C.

Mechanical strength corresponding to a continuous acceleration of 10 g at maximum load.

Maximum axial displacement during shock : 3 mm

Weight : E1E931S : 31 g.

Part number	Axial static load (daN)
E1E931S38 E1E4045-38	0,8 - 2
E1E931S55 E1E-4045-55	1 - 2,5
E1E931S72 E1E-4045-72	1,5 - 4

1) the indicated natural frequency, are valid for the maxi loads of the ranges of use quoted in the paragraph : TECHNICAL CHARACTERISTICS.

DIMENSIONS CHARACTERISTICS

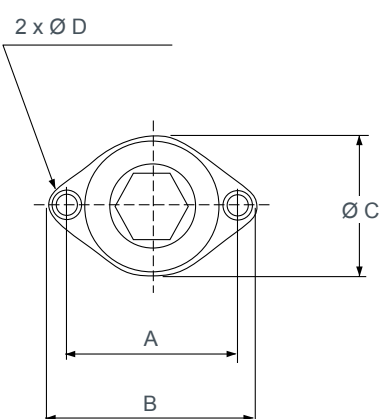
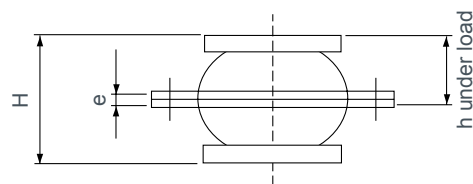
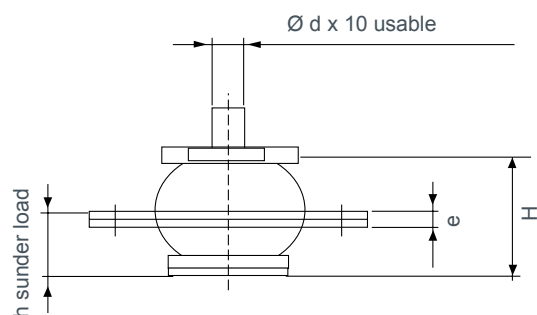

E1E931S

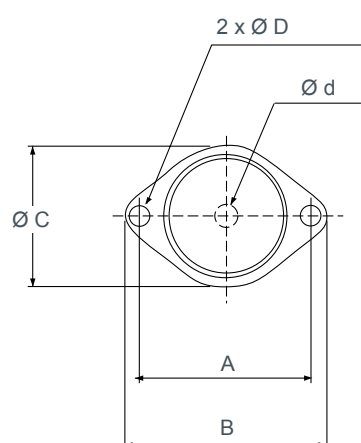

E1E4045

Reference	A (mm)	B (mm)	Ø C (mm)	Ø D (mm)	H (mm)	Ø d (mm)	e (mm)	h (mm)
E1E931S □□	34,9	44	30	4,2	24,5	M5	2,5	12,5
E1E4045-□□	35,9	44	30	4,2	20	5,1	2	11